



RX-5
SURFACE CORING DRILL

RX-5 Surface Coring Drill Rig

RX-5 is fully hydraulic diamond core drilling rig, designed for surface research drillings.

It is the perfect combination of the proven RX concept, combined with new and powerful components.

The RX-5 uses well proven technology for diamond core drills combined with new improvements in order to get easy drill operation. Hydraulic jacks, mast dump, hinged top mast and all controls available at the control panel provide the driller an easy set-up. Other features such as the strong main winch, powerful direct feed cylinder, advanced diesel engine, foldable mast and Gas Spring Rod Holder.

RX-5 Coring Rig rotation speed, power and rotation unit aperture diameter is designed to give optimal performance in 60-122.6 mm (B-P) diameter wireline or conventional drilling.

RX-5, drilling unit, power unit, wireline unit (automatic winding system), main winch control of the mixer and mud pump are performed from the operator panel.

The gauge located on the operator panel displays, drilling rig advancement position;

- Hold back force,
- Feed force,
- Rotation speed,

It can observe the data and is able to control diesel engine.

RX-5, can be mounted on 3 different chassis.

- Skid frame
- Wheel frame
- Crawler frame

RX-5 drilling rig, as progress is being achieved with the drilling rig hydraulic cylinder, more precise settings can be done.

RX-5 drilling rig, automatic rod removal and clamping feature allows high progress rate, optimal core percentage and big time save.



Technical Specifications

Drilling Depth Capacity

These figures serve as guidelines only. They are calculated with available pull/feed force, weight of drill string in water filled hole, average WOB and reserve for breaking solid core in rock with 5MPa Tensile Strength. Son-Mak cannot guarantee these capacities will be reached in all working conditions due to varying factors such as ITH used, conditions of the ground and differences in operation.

Drill Rod	Fluid Filled	
	Metric	U.S. System
BO / BRO Wireline	1550 m	5085 ft
NO / NRO Wireline	1200 m	3937 ft
NRO Thin Wall	1410 m	4625 ft
HO / HRO Wireline	800 m	2624 ft
HRO Thin Wall	940 m	3083 ft
PHD / PO Wireline	500 m	1640 ft
PHD Thin Wall	665 m	2181 ft

Rotation Unit

Rod sizes:	B-P
Power:	Hydraulic Motor
Transmission:	Funk 4 speed
Final Drive:	Straight cut gears
Ratio:	2.42:1
Rotation Unit Opener:	Side shift type - manual actuated
Hydraulic P Chuck	Hydraulic Open, Spring Closed
Spindle inner diameter:	117 mm (4-5/8 in)
Chuck axial holding force:	181 kN (40 690 lb)

Torque and RPM Ratings		Speed	Torque	
Spindle Speeds	Ratio	RPM	Nm	lbft
1st Gear	6.63:1	117-196	5113-3051	3771-2250
2nd Gear	3.17:1	246-410	2445-1459	1803-1076
3rd Gear	1.72:1	451-756	1326-792	978-584
4th Gear	1.00:1	776-1300	771-460	569-340

System Power Unit

Cummins QSB 6.7 L, turbo charged, after cooled diesel engine.	Metric	U.S. System
Volume:	6.7 liter	1.77 gallons
Power:	164 kW	220 bhp
RPM:	1800	1800
Electrical System:	12V	12V
Cooling System:	Water	
Emmissions Certifications:	Stage III	Tier 3



Hydraulic System	Metric	U.S. System
Primary Pump:	250 l/min - 280 bar	66 gal/min - 4061 psi
Secondary Pump:	127 l/min - 200 bar	33 gal/min - 2900 psi
Auxiliary Pump:	50 l/min - 200 bar	13 gal/min - 2900 psi
Hydraulic Oil Cooling:	Air	

Mast and Feed System	Metric	U.S. System
Feed Stroke:	3.50 m	11 ft
Thrust Force:	60 kN	13480 lb
Pull Force:	138 kN	31000 lb
Mast Dump Travel:	1.20 m	3.9 ft
Mast Telescope:	3.35 m	11 ft
Drilling Angle:	45 to 90 degrees	45 to 90 degrees
Rod Pull Length:	3.05 m or 6.09 m on foldable mast	10 ft or 20 ft on foldable mast

Rod Holder	Metric	U.S. System
Maximum Rod Size (HWT)	114.3 mm	4.5 in
Maximum Inside Diameter:	210 mm	8.3 in
Holding Force:	178 kN	40015 lb
Type:	Hydraulically open, gas pressure close	

Wireline Hoist	Metric	U.S. System
Drum Capacity (4.76mm - 3/16" wire)	1800 m	5905 ft
Line pull min. (full drum)	3.0 kN	674 lb
Line pull max. (bare drum)	11.9 kN	2675 lb
Line speed min. (bare drum)	115 m/min	377 ft/min
Line speed max. (full drum)	455 m/min	1492 ft/min

Main Winch	Metric	U.S. System
Single line capacity: (bare drum)	80 kN	18000 lb
Line speed:(bare drum)	43 m/min	141 ft/min
Cable size:	16 mm	10/16 in
Cable length:	35 m	114 ft

Mud Pump	Metric	U.S. System
TP135H		
Flow:	135 l/min	35 gal./min
Pressure:	70 bar	1000 psi

Transportation Dimensions

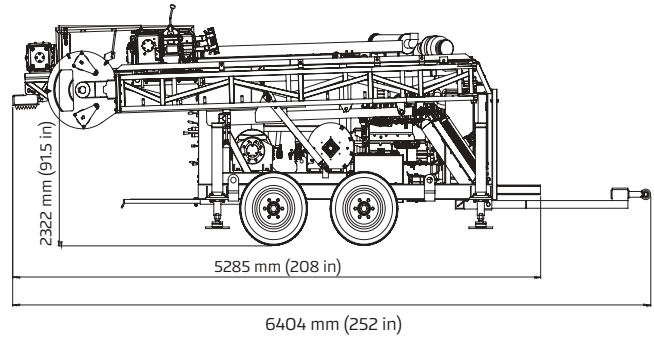
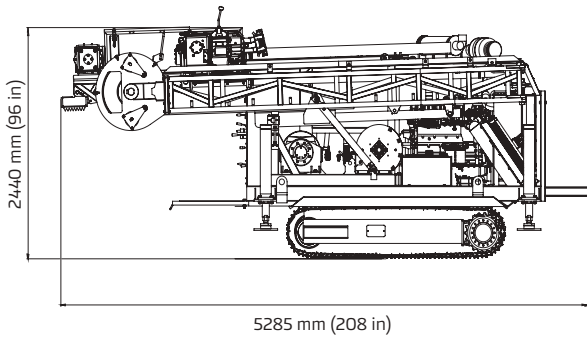
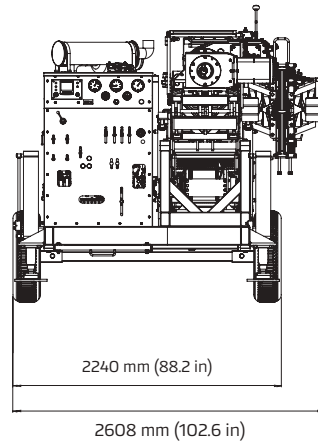
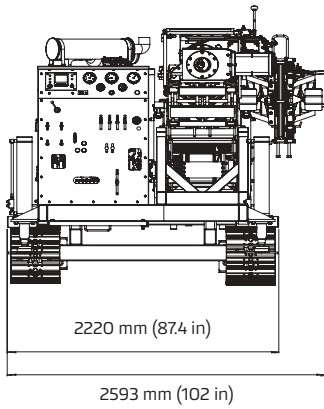

Transportation Dimensions

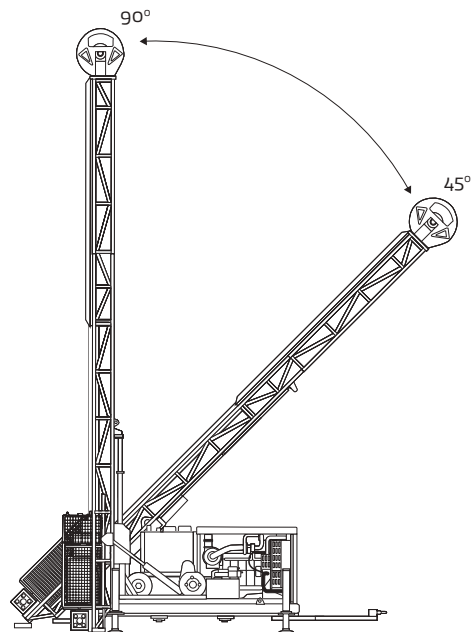
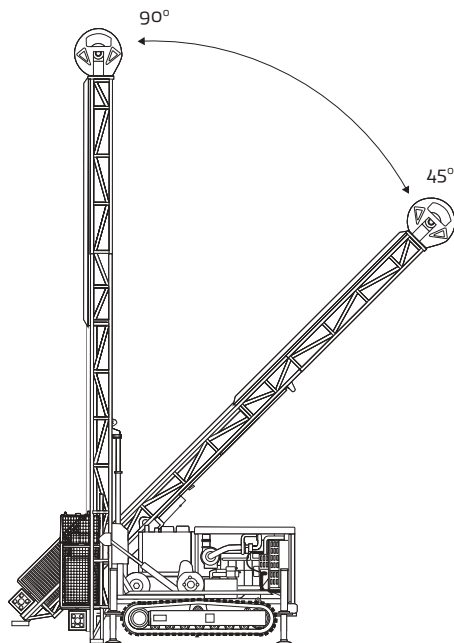

Weight

RX-5 Crawler: 9000 kg (18000 lb)

Weight

RX-5 Trailer: 7500 kg (16534 lb)

